

| | | |
|-----|--------------|------------|
| REV | MODIFICATION | DATE |
| A | ISSUE | 2015.10.06 |

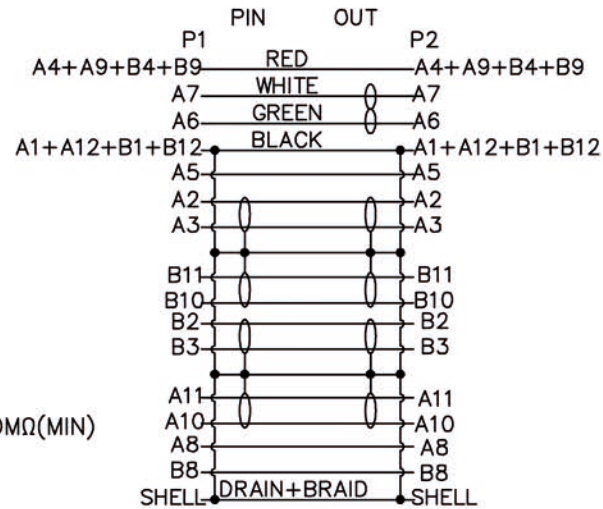

ELECTRONIC TEST:

- A.OPEN/SHORT/INTERMITTENCE: 100%.
- B.HI-POT: AC 150V 0.01S
- C.INSULATION RESISTANCE:DC300V 0.01S 10MΩ(MIN)
- D.CONDUCTIVE RESISTANCE:2 OHM (MAX)

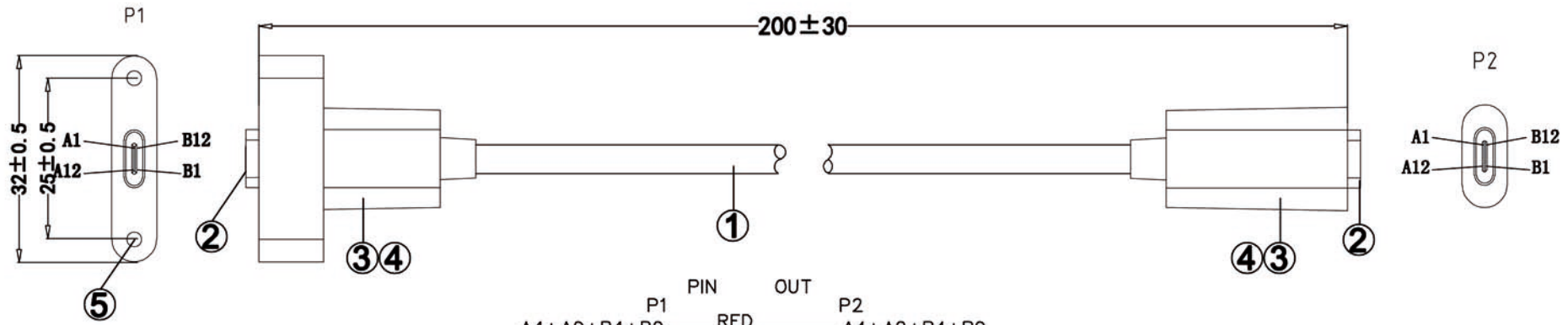
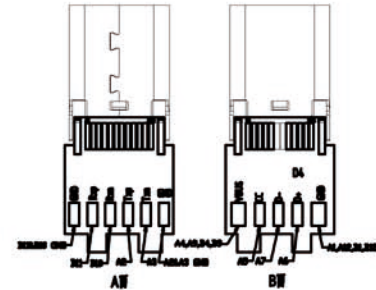

| | | | | |
|----|-------------|--|------|------|
| ⑤ | THUMB SCREW | NUT-NICKEL PLATED(#4-40) | 2 | PCS |
| ④ | MOLDED | 45P BLACK PVC | 12 | G |
| ③ | MOLDED | LDPE | 4 | G |
| ② | CONNECTOR | USB3.1 C TYPE Female G/F NI PLATED+PCB BOARD | 2 | PCS |
| ① | CABLE | USB3.1 CABLE(1P*34AWG+D+AL+MY)*4C+1P*32AWG+4C*32AWG+1C*24AWG+2D+F+MY+AL+B BLACK PVC OD:4.5±0.2MM | 200 | MM |
| NO | NAME | specification | Q'TY | UNIT |

| | | | | | | |
|---------------------|-----------------------------|---|--------------------------|----------------------|-----------------------|--|
| Ltemref | Quantity | Title/Name,designation,material,dimension etc | | | Article No./Reference | |
| Designed by ACHY | Checked by NIKE | Approved by - date OCT 6TH 2015 | File name USB3.1 | Date OCT 6TH 2015 | Scale FREE | |
| ANGLE: | LYNDAHL [®] | | USB 3.1 F /F Panel Mount | | | |
| UNIT-MM | © Traderia GmbH 2015 | | LKPK031 | Edition 1 | Sheet 1/1 | |